

SUNMOTOR

MODEL SUB500 SOLAR PUMP

The Sunmotor SUB500 submersible pump is ideal for solar pumping from groundwater sources such as wells and boreholes. The SUB500 utilizes a high capacity multi-stage centrifugal pump driven by a rugged d.c. motor, enclosed inside a waterproof shell.

FEATURES

- **No Inverter:** Special d.c. motor connects directly to solar array for efficient operation.
- **Rugged Construction:** Stainless steel and bronze provides strength and corrosion resistance.
- **Uses any d.c. power source:** Operates on solar, wind or battery power.
- **Built-In Overload Protection:** Internal magnetic drive protects the motor from damage if the pump ever becomes plugged.
- **Simple Installation:** Use of plastic discharge pipe allows installation totally by hand with simple tools.
- **No maintenance:** Motor and pump will operate for years without servicing.

APPLICATION EXAMPLES

- Village water supply
- Livestock watering
- Remote homes
- Micro-irrigation

Pumping Head		30 Volts			36 Volts			45 Volts		
		Current	Flow		Current	Flow		Current	Flow	
Meters	Feet	(A)	L/min	USgpm	(A)	L/min	US gpm	(A)	L/min	USgpm
5	16.4	5.4	25.0	6.6	7.0	33.0	8.7	10.0	41.0	10.8
10	32.8	5.5	23.0	6.1	7.2	30.0	7.9	10.0	40.0	10.6
15	49.2	5.5	18.0	4.8	7.3	27.0	7.1	10.2	38.0	10.0
20	65.6	5.3	14.0	3.7	7.4	24.0	6.3	10.4	36.0	9.5
25	82.0	4.2	7.0	1.9	7.3	21.0	5.6	10.4	33.0	8.7
30	98.4	—	0.0	0.0	6.8	16.0	4.2	10.4	31.0	8.2
35	114.8	—	0.0	0.0	5.7	9.0	2.4	10.4	28.0	7.4
40	131.2	—	0.0	0.0	—	0.0	0.0	10.4	26.0	6.9
45	147.6	—	0.0	0.0	—	0.0	0.0	10.0	21.0	5.6
50	164.0	—	0.0	0.0	—	0.0	0.0	9.5	18.0	4.8
55	180.4	—	0.0	0.0	—	0.0	0.0	8.2	12.0	3.2
60	196.8	—	0.0	0.0	—	0.0	0.0	6.6	4.0	1.1

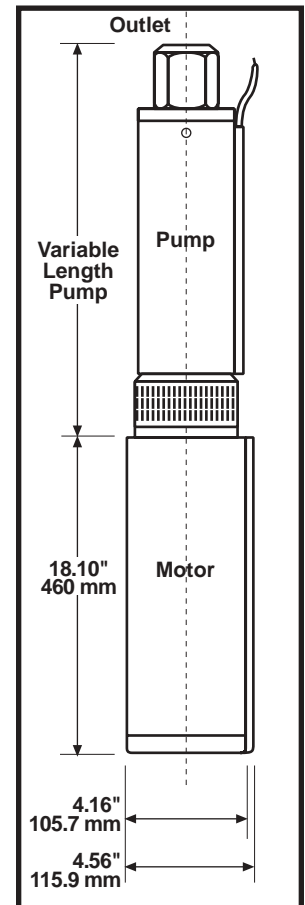

5037 – 50th Street
Olds, Alberta, Canada
T4H 1R8

Phone: (403) 556-8755
Fax: (403) 556-7799

Email: sunmotor@telusplanet.net
www.sunpump.com